



School of Agricultural Sciences

FUNDAMENTALS OF AGRONOMY

TOPIC: IRRIGATION SCHEDULING

Ms. SHAGUN GUPTA

Assistant Professor

(Agronomy)

IRRIGATION SCHEDULING

- Irrigation scheduling is defined as the frequency with which water is to be applied based on needs of the crop and nature of the soil.
- Irrigation scheduling is nothing but number of irrigations and their frequency required to meet the crop water requirement.
- Irrigation scheduling may be defined as scientific management technique of allocating irrigation water based on the individual crop water requirement (ET_c) under different soil and climatic condition, with an aim to achieve maximum crop production per unit of water applied over an unit area in unit time.

- **Irrigation Scheduling** is a decision-making process repeated many times in each year involving when to irrigate and how much of water to apply? Both criteria influence the quantity and quality of the crop. It indicates how much of irrigation water to be used and how often, it has to be given.

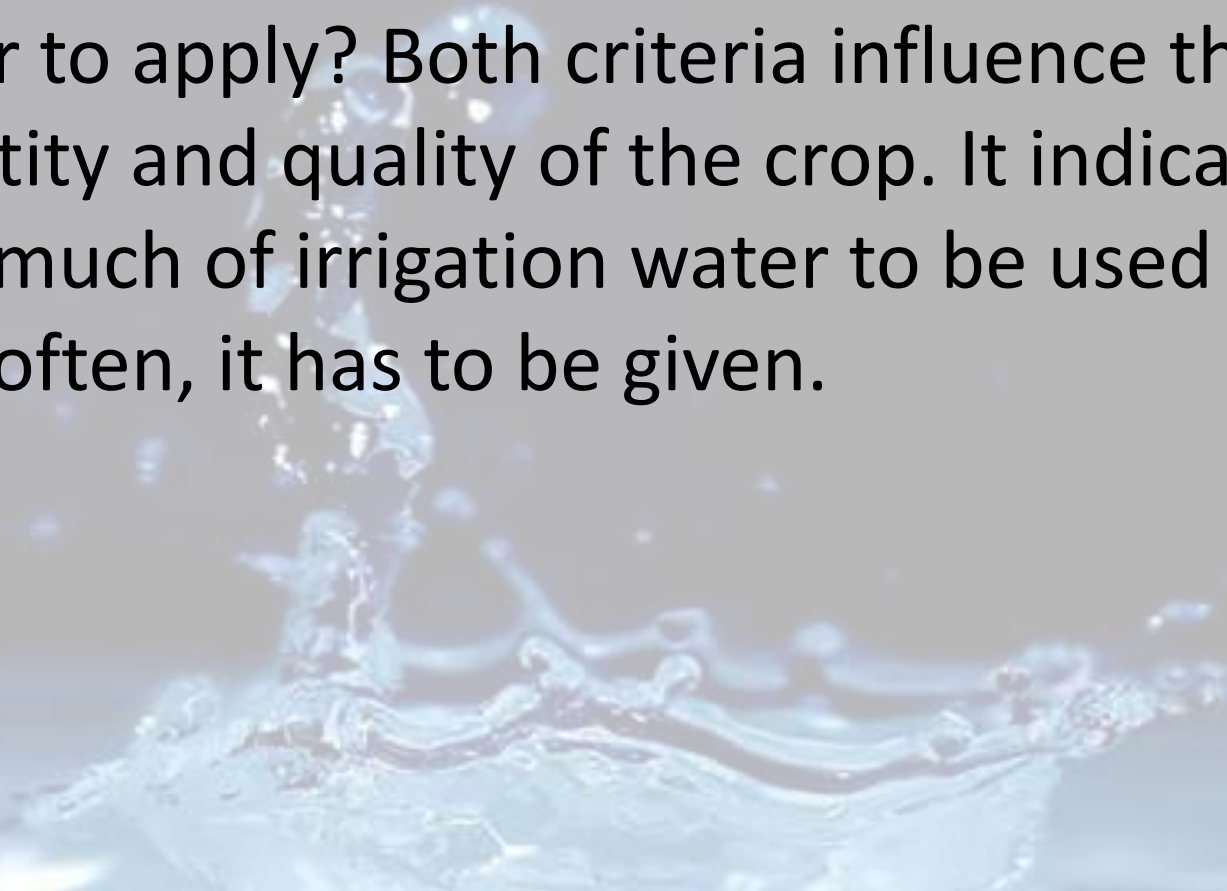

Scheduling of Irrigation to Crops

Advantages of Irrigation Scheduling

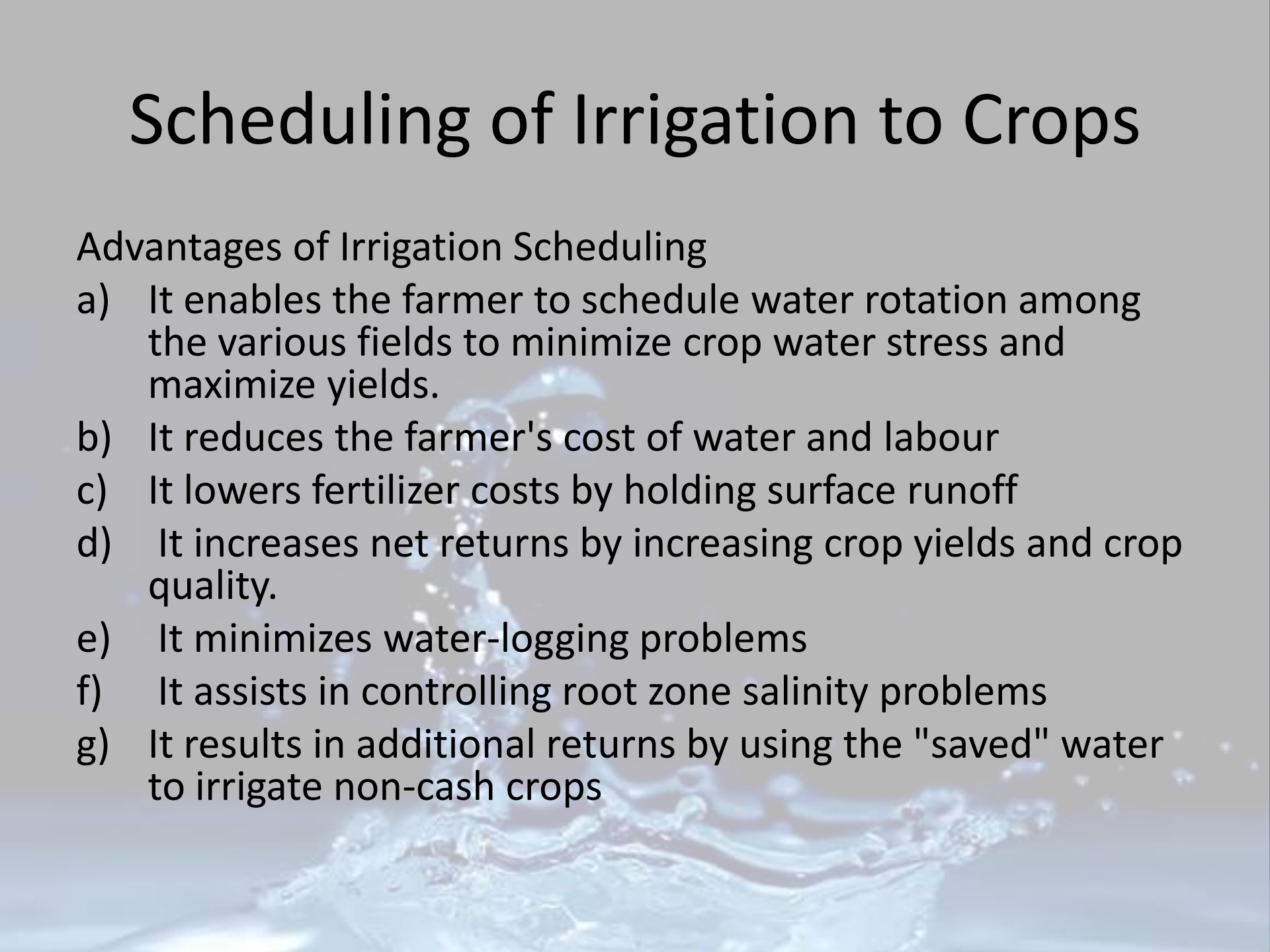
- a) It enables the farmer to schedule water rotation among the various fields to minimize crop water stress and maximize yields.
 - b) It reduces the farmer's cost of water and labour
 - c) It lowers fertilizer costs by holding surface runoff
 - d) It increases net returns by increasing crop yields and crop quality.
 - e) It minimizes water-logging problems
 - f) It assists in controlling root zone salinity problems
 - g) It results in additional returns by using the "saved" water to irrigate non-cash crops
- 
- A decorative background image showing a dynamic splash of water with many small droplets and ripples, set against a light blue and white gradient.

Irrigation Scheduling Criteria

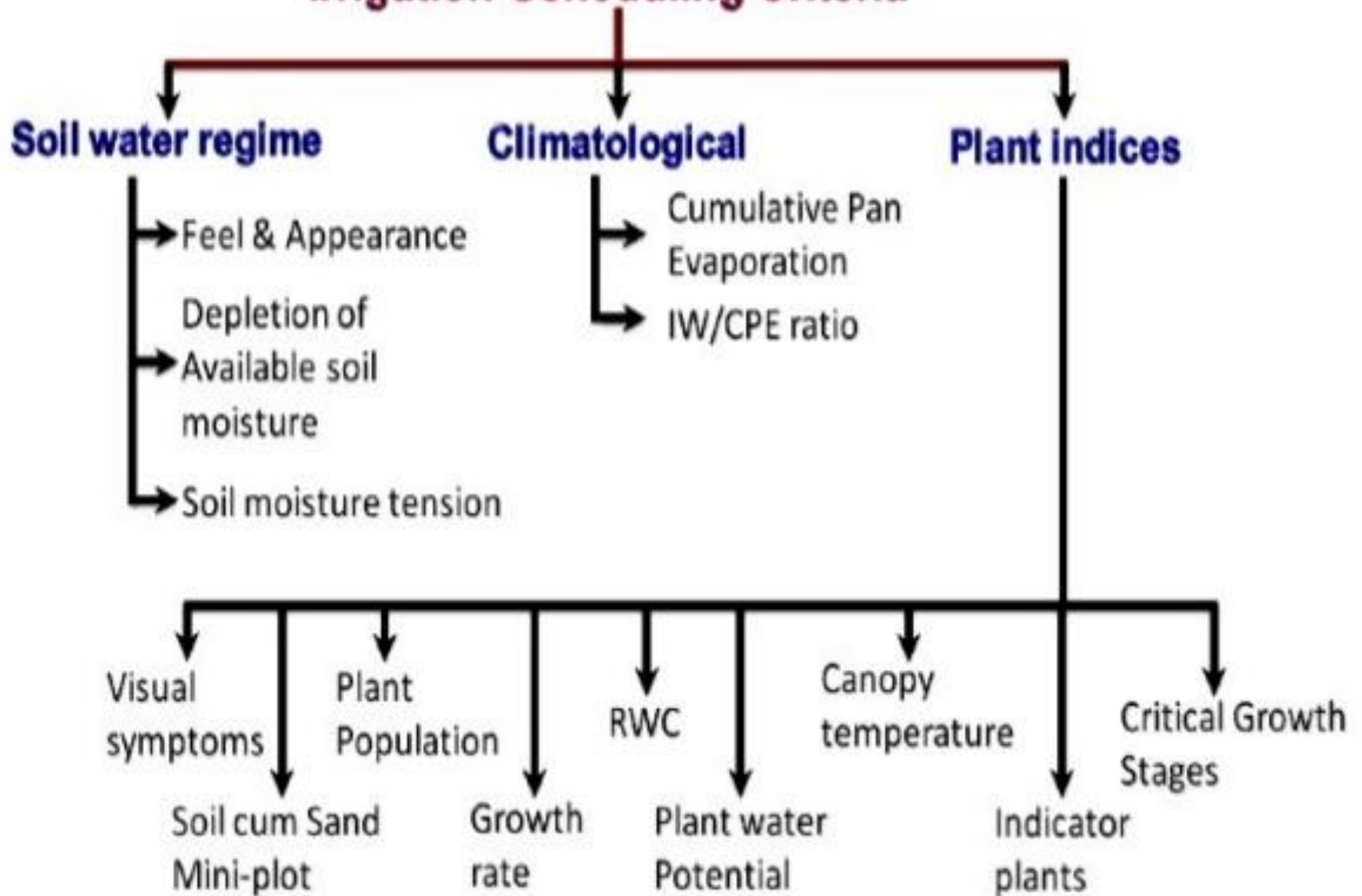

Soil Water Regime Approach

- In this approach the available soil water held between field capacity and permanent wilting point in the effective crop root zone
- Alternatively soil moisture tension, the force with which the water is held around the soil particles is also sometimes used as a guide for timing irrigations.

Feel And Appearance Of Soil

- This is one of the oldest and simple methods of determining the soil moisture content.
- It is done by visual observation and feel of the soil by hand.
- The accuracy of judgment improves with experience.

**Fine Sand and Loamy
Fine Sand**

**Sand Loam and Fine
Sandy Loam**

**Sand Clay Loam, Loam
and Silt Loam**

0 – 25% DASM



25 – 50% DASM



50 – 75% DASM



Table 18.1. Guidelines for judging soil moisture by feel & appearance of soil

Available soil moisture range	Coarse texture (loamy sand)	Moderately coarse (sandy loamy)	Medium texture (loamy and silt loamy)	Fine texture (clay loamy and silty clay loamy)
Above field capacity	Free water appears when soil is banded in hand	Free water is released with kneading	Free water can be squeezed out	Puddles; free water forms on surface.
At Field capacity (100%)	On squeezing no free water appears on soil, but wet outline of ball is left on hand	Same as for coarse textured soils at field capacity	Same as for coarse textured soils at field capacity	Same as for coarse textured soils at field capacity
75% to 100%	Tends to stick together slightly, may form a very weak ball under pressure	Forms weak ball that breaks easily, does not slick	Forms a ball, very pliable, sticks readily if relatively high in clay	Easily ribbons out between fingers; has a slick feeling
50% to 75%	Appears to be dry, does not form a ball under pressure	Forms a ball under pressure but seldom holds together	Forms a ball under pressure; somewhat plastic, slicks slightly under pressure	Forms a ball; ribbons out between thumb and forefinger
25% to 50%	As above, but ball is formed by squeezing very firmly	Appears to be dry, do not form a ball unless squeezed very firmly	Somewhat crumbly but holds together with pressure	Somewhat pliable, forms a ball under pressure
0 to 25%	Dry, loose & single grained, flows through fingers.	Dry and loose, flows through fingers	Powdery dry, sometimes slightly crusted, but breaks down easily into powder.	Hard, baked and cracked, has loose crumbs on surface in some places

Depletion Of The Available Soil Moisture (DASM)

- In this method the permissible depletion level of available soil moisture in the effective crop root zone depth is commonly taken as an index
- In general, for many crops scheduling irrigation's at 20 - 25% DASM in the soil profile was found to be optimum at moisture sensitive stages.
- While at other stages irrigations scheduled at 50% DASM were found optimum.

Soil Moisture Tension

- Soil moisture tension a physical property of film water in soil, as monitored by tensiometers at a specified depth in the crop root zone could also be used as an index for scheduling irrigations to field crops.
- Tensiometers are installed in pairs, one in the maximum rooting depth and the other below this zone.
- Whenever critical soil moisture tension is reached the irrigation is commenced.
- While the lower one (tensiometer) is used to terminate the irrigations based on the suction readings in the below soil profile zone.
- It is generally used for irrigating orchards and vegetables in coarse textured soils because most of the available soil moisture is held at lower tensions.

Tensiometer

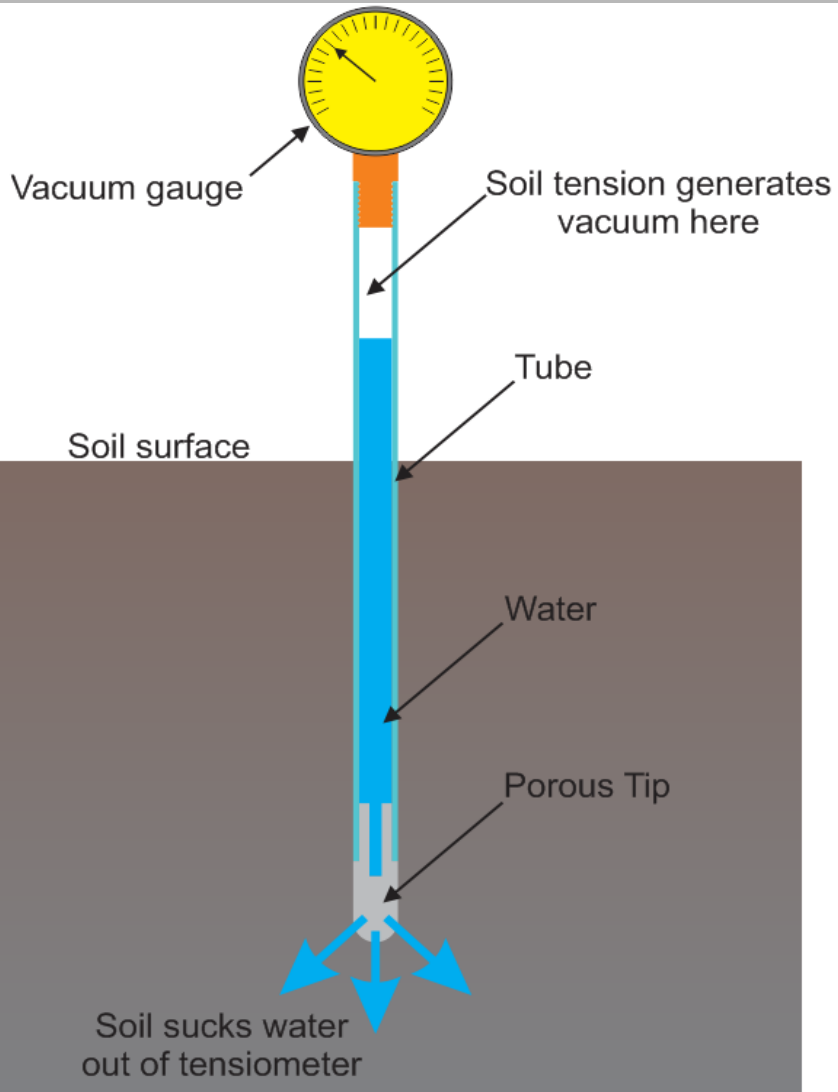

Climatological Approach

- The potential rate of water loss from a crop is primarily a function of evaporative demand of the atmosphere
- In this method the water loss expressed in terms of either potential evapotranspiration (PET) or cumulative panevaporation (CPE)
- *Different climatological approaches are described below:*

Potential Evapotranspiration (PET)

- Penmen (1948) introduced the concept of PET
- It is defined as "the amount of water transpired in a unit time by short green crop of uniform height, completely covering the ground and never short of water".

PET can be estimated by several techniques viz.

1. lysimetric methods
2. energy balance
3. aerodynamic approach
4. combination of energy balance and empirical formulae etc.

Lysimeter

- Isolating the crop root zone from its environment
- Controlling the processes that are difficult to measure
- Greater accuracy

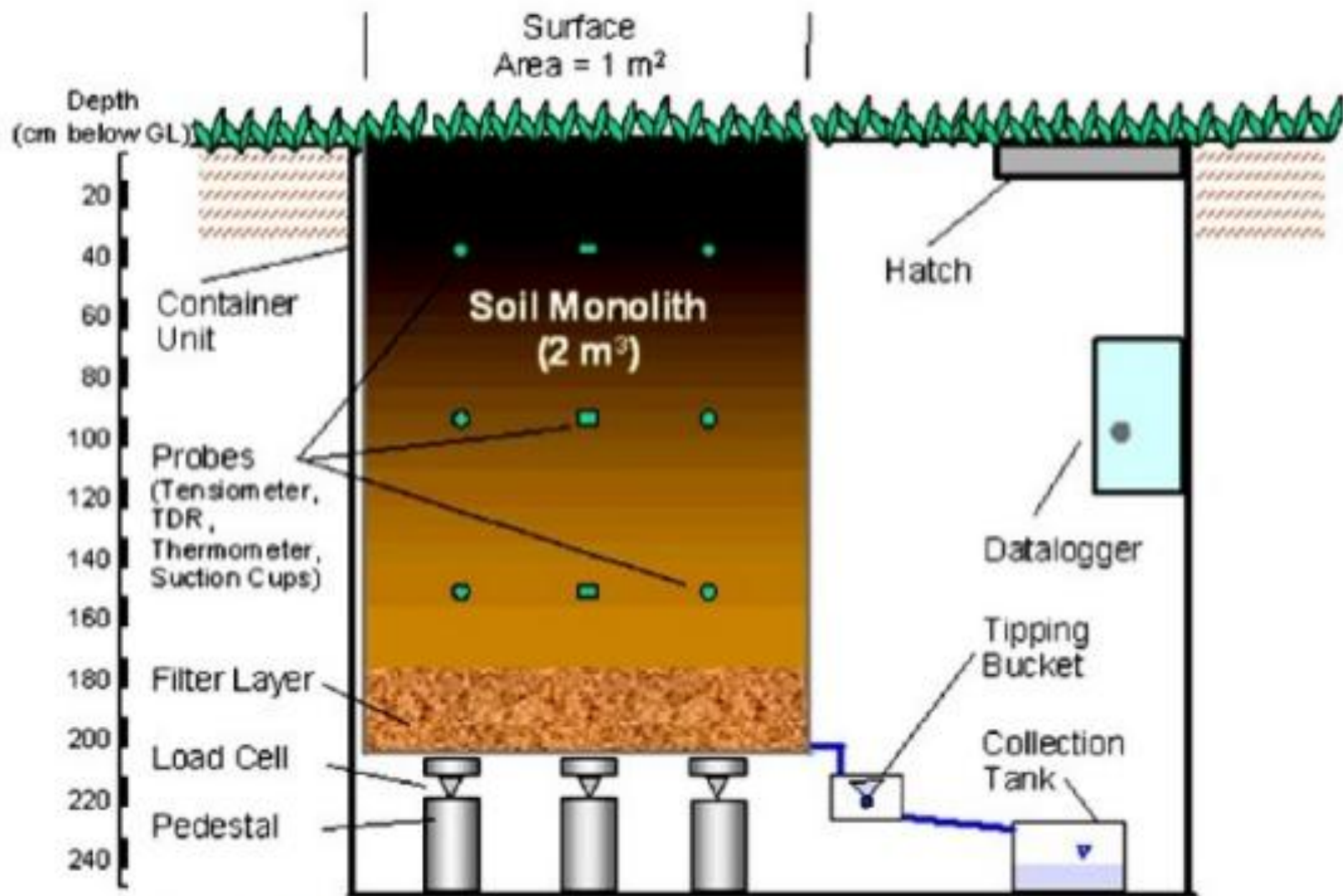

Fig. 19.1. schematic view of Lysimeter

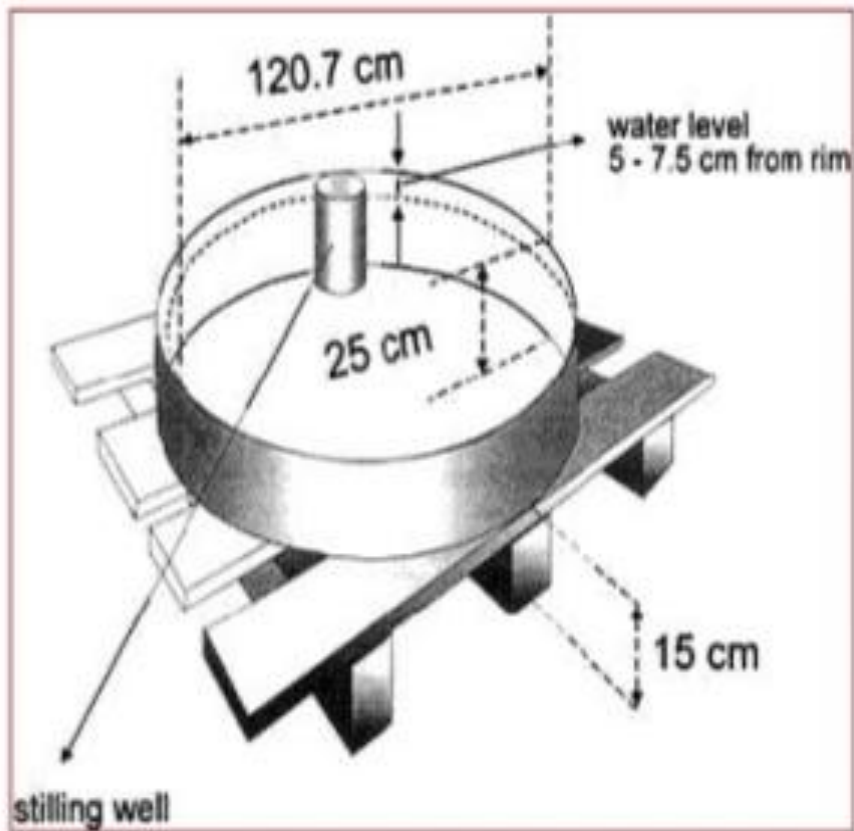

Fig. 19.2. USWB Class A Pan evaporimeter

IW : CPE ratio

- Prihar et al. (1974) advocated irrigation scheduling on the basis of ratio between the depth of irrigation water (IW) and cumulative pan evaporation
- However, the criterion does not take into consideration the critical growth stages for irrigation.
- the amount of water given at each irrigation ranges from 4 to 6 cm, the most common being 5cm of irrigation.
- Scheduling irrigation at an IW/CPE ratio at 1.0 with 5cm of irrigation water means 5 cm of irrigation water is applied when the CPE reaches 5 cm.
- It may also not hold well under the following situations.
 1. For crops requiring 1-2 irrigations only
 2. Determining timing of first and last irrigation
 3. Under low temperature/ frost/ salt stresses

Plant Indices Approach

Visual Plant Symptoms

- In this method the visual signs of plants are used as an index for scheduling irrigations.
- For instance, plant wilting, drooping, curling and rolling of leaves in maize is used as indicators for scheduling irrigation.
- Change in foliage colour and leaf angle is used to time irrigations in beans.
- Water stress in some crops leads to appearance of carotenoid (yellow and orange colour)
- Shortening of internodes in sugarcane and cotton; retardation of stem elongation in grapes
- Leaf abscission and lack of new growth and redness in terminal growth points of almond



Soil-cum-sand mini-plot technique or profile modification technique

- It is commonly used for scheduling irrigations to crops.
- The principle involved in this technique is to reduce artificially the available water holding capacity of soil profile (i.e., effective root zone depth) in the mini-plot by mixing sand with it.
- When this is done plants growing on the sand mixed plot show wilting symptoms earlier than in the rest of the field.
- An area of 1.0 x 1.0m is selected in the field and a pit of 1.0m depth is excavated.
- About 5% of sand by volume is added to the dug up soil and mixed well.

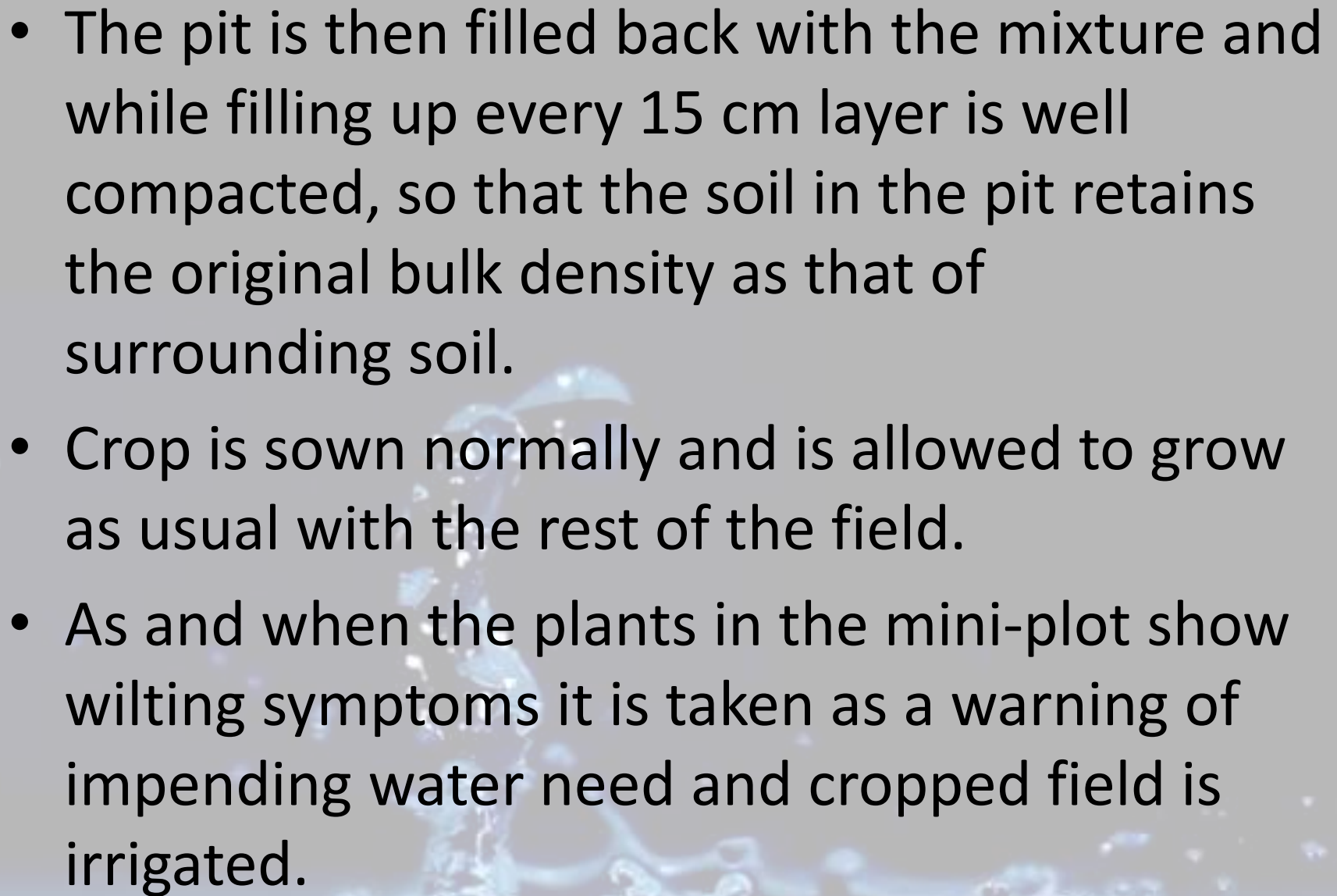
- The pit is then filled back with the mixture and while filling up every 15 cm layer is well compacted, so that the soil in the pit retains the original bulk density as that of surrounding soil.
 - Crop is sown normally and is allowed to grow as usual with the rest of the field.
 - As and when the plants in the mini-plot show wilting symptoms it is taken as a warning of impending water need and cropped field is irrigated.
- 
- A decorative background image showing a dynamic splash of water with numerous droplets and ripples, rendered in a light blue and white color palette.

Plant Population

- Increase in plant population by 1.5 to 2.0 times that of optimum
- This happens because when more plants are there per unit area, the available water within that zone is depleted rapidly as compared to other area.
- This result in drooping or wilting of plants earlier, which can be taken as an indication of water deficits and accordingly irrigations are scheduled to crops.

Rate Of Growth

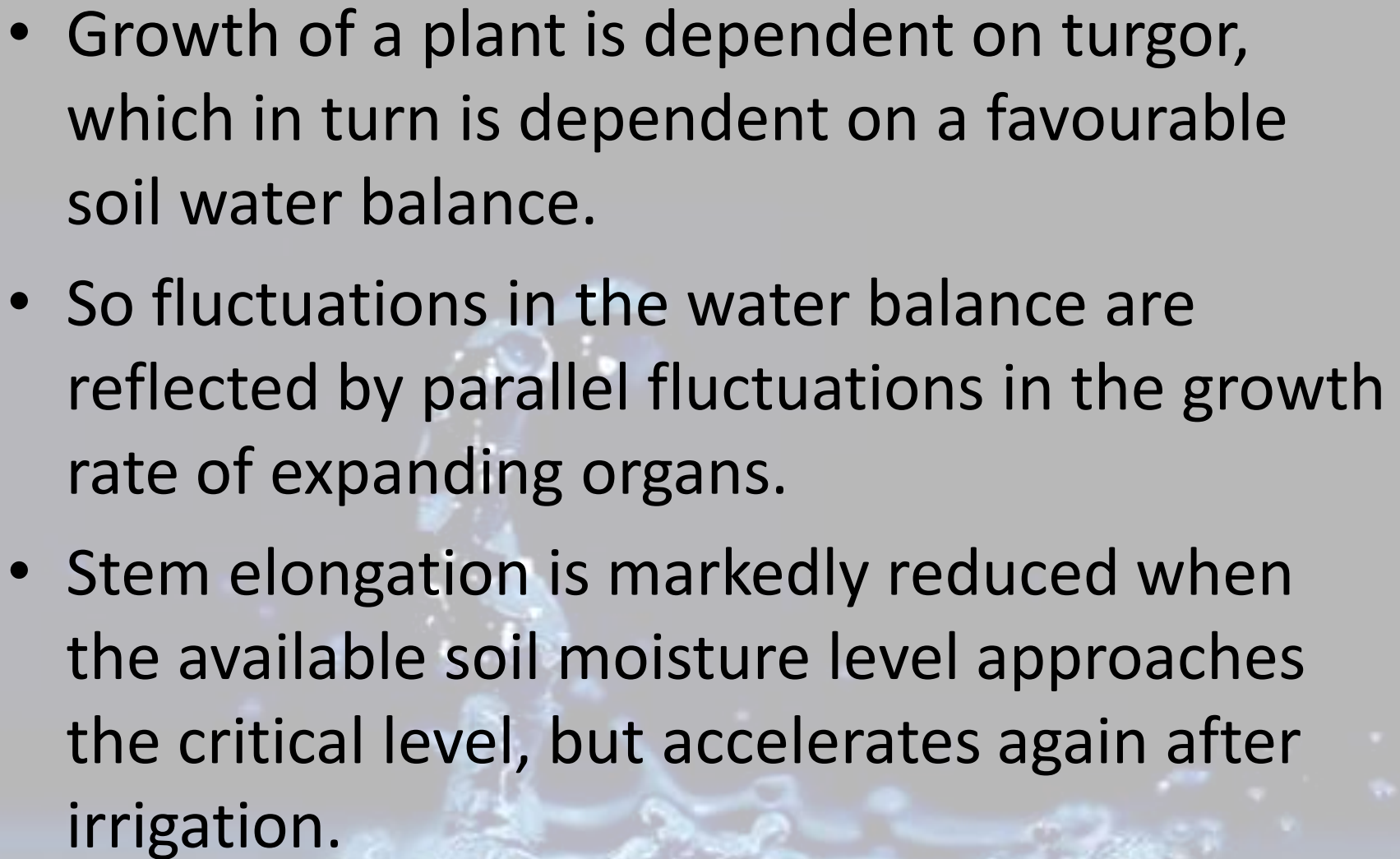
- Growth of a plant is dependent on turgor, which in turn is dependent on a favourable soil water balance.
 - So fluctuations in the water balance are reflected by parallel fluctuations in the growth rate of expanding organs.
 - Stem elongation is markedly reduced when the available soil moisture level approaches the critical level, but accelerates again after irrigation.
- 
- A background image showing a dynamic splash of water, with droplets and ripples, set against a light blue and white gradient. The water appears to be moving upwards and outwards from a central point, creating a sense of motion and freshness.

Indicator plants

- In wheat, scheduling irrigations on the basis of wilting symptoms in maize.

Critical Growth Stages

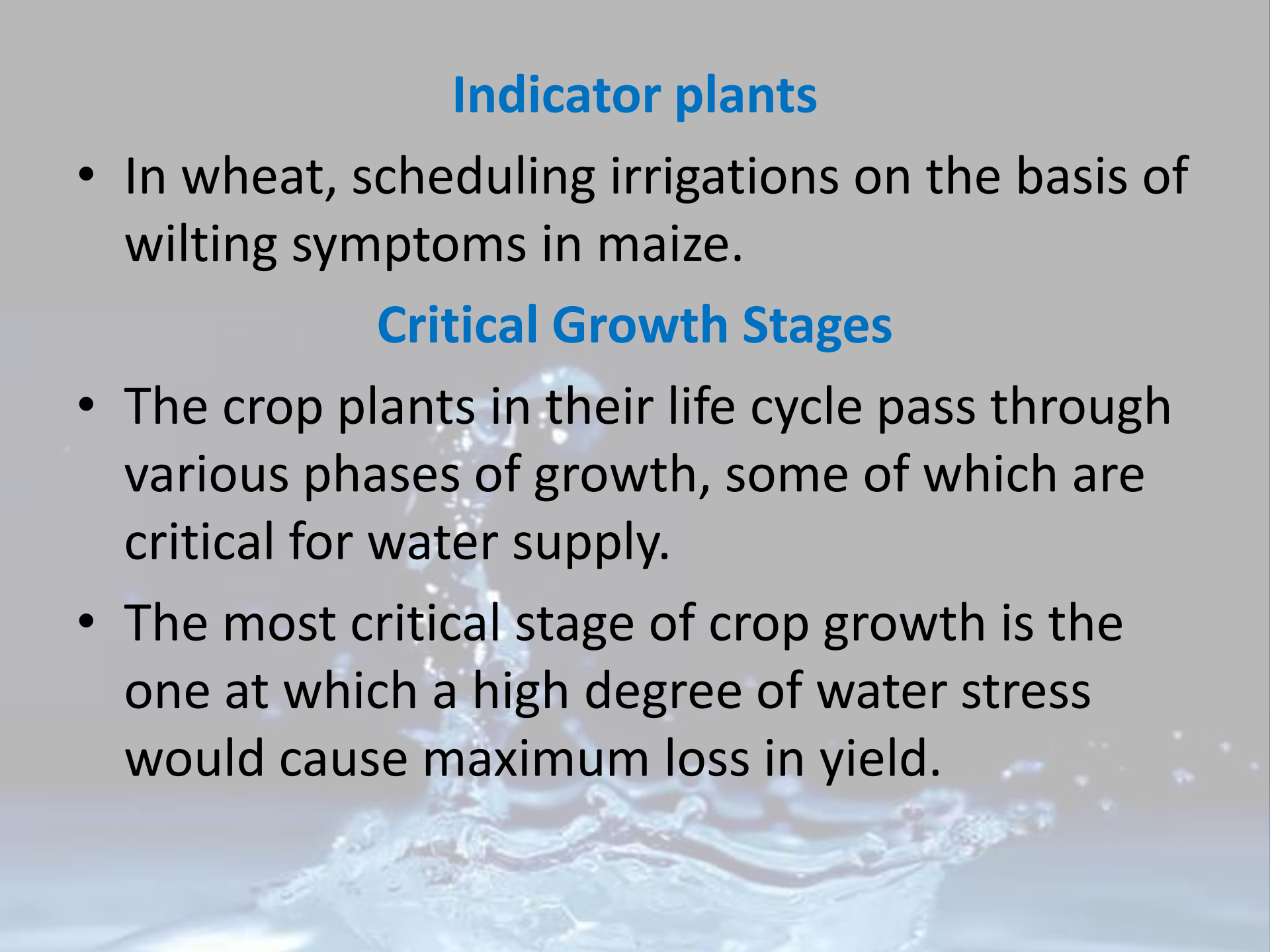
- The crop plants in their life cycle pass through various phases of growth, some of which are critical for water supply.
 - The most critical stage of crop growth is the one at which a high degree of water stress would cause maximum loss in yield.
- 
- A decorative background image showing a dynamic splash of water with droplets and ripples, rendered in a light blue and white color palette. The splash is centered and occupies the lower half of the slide, creating a sense of freshness and movement.

Moisture sensitive stages of important crop

Crops	Important moisture sensitive stages
Rice	Panicle initiation, flowering
Wheat	Crown-root initiation, jointing, milking
Sorghum	Seedling, flowering
Maize	Silking, tasseling
Pearl Millet	Flowering, panicle initiation
Finger Millet	Panicle initiation, flowering
Groundnut	Rapid flowering, pegging, early pod formation
Red gram	Flowering and pod formation
Green gram	Flowering and pod formation
Black gram	Flowering and pod formation
Sugarcane	Formative stage
Sesame	Blooming stage